

USER GUIDE

NEWTON PRODUCTS LIMITED

THE

VIXEN FAMILY

OF

POWERED WHEELCHAIRS

EPIOC WHEELCHAIR

Electrically Powered Indoor Outdoor Wheelchair

We have produced this user guide to help you obtain most benefit from the VIXEN wheelchair that has been prescribed for you.

Your wheelchair has been manufactured to meet the requirements of various 'British', 'European' and 'International' standards, to help ensure your safety and comfort when using your wheelchair.

The Maximum approved user weight for this Wheelchair is 115 Kg (252 lb)



Registered with the UK Competent Authority (Medical Devices Agency) as a manufacturer of a 'class 1' medical device.

IMPORTANT

Do not attempt to use the wheelchair before a qualified person has explained, to your satisfaction, how to use the controls and the battery charger and also the performance limits of this wheelchair.

You must read and familiarise yourself with this USER GUIDE where it refers to your model of wheelchair.

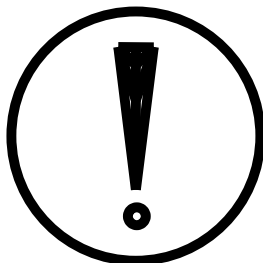

CONTENTS

- 1. Introduction**
 - 1.1 The Vixen EPIOC Wheelchair

- 2. Setting Up The Wheelchair**
 - 2.1 Initial Set Up
 - 2.2 Adjustment And Removal Of Armrests
 - 2.2.1 Adjustment Of Armrests
 - 2.2.2 Removal Of Armrests
 - 2.2.3 Controller Mounting Bracket
 - 2.3 Removal And Re-fitting Of Backrest
 - 2.3.1 Removing The Backrest
 - 2.3.2 Re-Fitting The Backrest
 - 2.4 Removal And Re-Fitting Of Seat Unit
 - 2.4.1 Removing The Seat Unit
 - 2.4.2 Re-Fitting The Seat Unit
 - 2.5 Footrests
 - 2.5.1 Removing The Footrests
 - 2.5.2 Re-fitting The Footrests
 - 2.5.3 Adjustment Of Footrests
 - 2.5.3.1 Swing Aside Footrests
 - 2.5.3.2 Vertical Adjustment Of Footrests

- 3. Anti -Tip Devices**

- 4. Brakes**
 - 4.1 Motor Brakes
 - 4.1.1 Checking Operation Of Motor Brakes
 - 4.2 Parking Brake

- 5. Freewheel Device**
 - 5.1 Using The Freewheel Device

- 6. Kerb Climbing Device**
 - 6.1 Removing The Kerb Climber From The Wheelchair
 - 6.2 Re-fitting The Kerb Climber To The Wheelchair

- 7. Batteries**
 - 7.1 Removing The Batteries From The Wheelchair
 - 7.2 Re-Fitting The Batteries To The Wheelchair
 - 7.3 Battery Charger
 - 7.4 Charging The Batteries
 - 7.5 Battery Use – Best Practice

- 8. Controllers**
 - 8.1 Your Controller
 - 8.1.1 Important Precautions For Use
 - 8.1.2 Controls

- 9. Using The Wheelchair**
 - 9.1 Intended Use
 - 9.2 Getting Into The Wheelchair
 - 9.3 Getting Out Of The Wheelchair
 - 9.4 Driving The Wheelchair
 - 9.5 Negotiating Obstacles
 - 9.5.1 Climbing Small Kerbs – Under 40mm High
 - 9.5.1.1 To Climb A Small Kerb
 - 9.5.1.2 To Descend A Small Kerb
 - 9.5.2 Climbing Kerbs – Over 40mm High
 - 9.5.2.1 Climbing A Kerb
 - 9.5.2.2 Descending A Kerb
 - 9.5.3 Using The Wheelchair On Slopes
 - 9.5.3.1 To Go Up A Slope
 - 9.5.3.2 To Go Down A Slope
 - 9.5.3.3 Going Across a slope

- 10. Transporting The Wheelchair**
 - 10.1 Using Loading Ramps

- 11. Using The Wheelchair In A Vehicle**
 - 11.1 Restraint Instructions
 - 11.1.1 What You Should Know Before Entering The Vehicle
 - 11.1.2 What You Should Know About Safe Restraint Procedure
 - 11.1.3 Other Important Considerations
 - 11.1.4 Securing Your Wheelchair In A Vehicle

- 12. Other Safety Advice**
 - 12.1 Fire Precautions
 - 12.2 Mobile Telephones
 - 12.3 Other Safety Warnings

- 13. Action To Be Taken By User In Event Of Wheelchair Failure Or An Accident**

- 14. Caring For Your Wheelchair**
 - 14.1 Daily Care
 - 14.2 Weekly Care
 - 14.3 Monthly Care
 - 14.4 Service and Maintenance

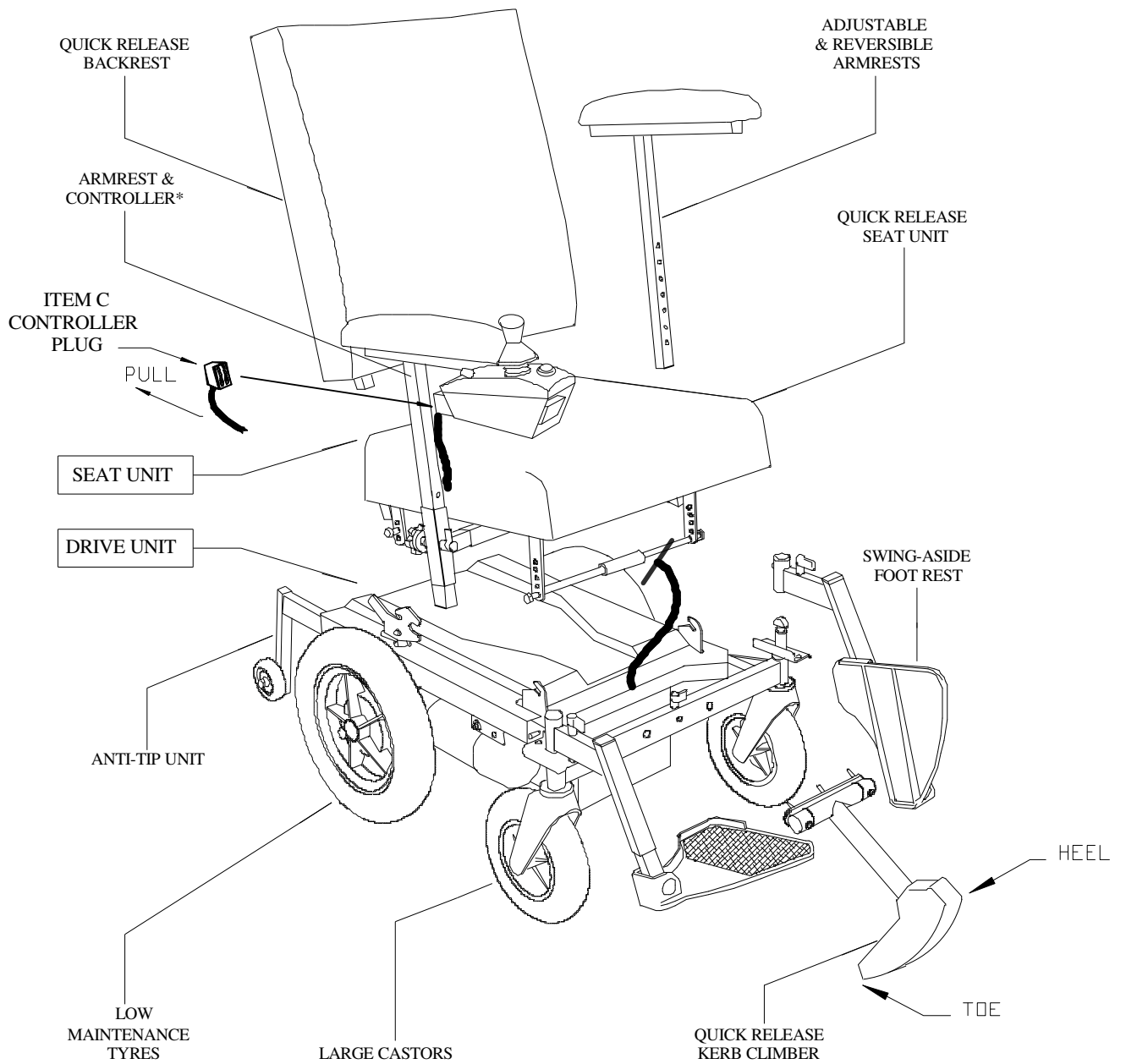

VIXEN EPIOC WHEELCHAIR

FIG.1.

1. INTRODUCTION

The 'VIXEN FAMILY' of powered wheelchairs has evolved from the refinement of previous models and has unique modular design.

The continuing evolutionary growth of the 'VIXEN FAMILY' of wheelchairs, responds to the needs of the user and is achieved through close collaboration with; Occupational and Physiotherapists, Rehabilitation Engineers, Industrial Designers and Contract Repairers.

The 'VIXEN FAMILY' of wheelchairs consists of the following models:

The Vixen Cub (Indoor Wheelchair)

The Vixen EPIC (Indoor Wheelchair)

The Vixen EPIOC (Indoor Outdoor Wheelchair)

The Vixen Heavy Duty (Indoor Outdoor Wheelchair)

The Vixen XL (Extra Heavy Duty Indoor Wheelchair)

The Vixen Tilt In Space (Indoor Outdoor Wheelchair)

Each 'Vixen' wheelchair consists of a seat unit, which is mounted on a drive unit. The seat unit can be removed quickly in order to allow for transport and to give access to the battery compartment. Arm rests and footrests are adjustable and can be removed to allow for transport.

Each wheelchair is equipped with an integral controller as standard. They can be fitted with Attendant or Dual Controls if specified.

1.1 THE VIXEN EPIOC WHEELCHAIR

The 'Vixen' EPIOC is a wheelchair that can be used both in and out of doors. It is equipped with anti-tip devices and kerb climbing equipment to help make outdoor use easier and safer.

The following user instructions are intended to help you make safe use of your wheelchair. Please read them carefully and follow them. You should ask for an explanation from your issuing authority of any points you do not understand. Please keep these instructions with your wheelchair and refer to them as necessary.

2. SETTING UP THE WHEELCHAIR

A qualified person will set up your wheelchair for you at the time of issue. Normally these settings should not be altered without the approval of the authority that prescribed the wheelchair for you.

2.1 INITIAL SET UP

Set up instructions are given in this User Guide to allow you or your carer to return the wheelchair to the prescribed settings after the wheelchair has been transported or stored etc.

2.2 ADJUSTMENT AND REMOVAL OF ARMRESTS

2.2.1 ADJUSTMENT OF ARMRESTS

To adjust the armrests height loosen the hand wheel and whilst holding the armrest with one hand operate the latch lever with the other hand (see figure 2).

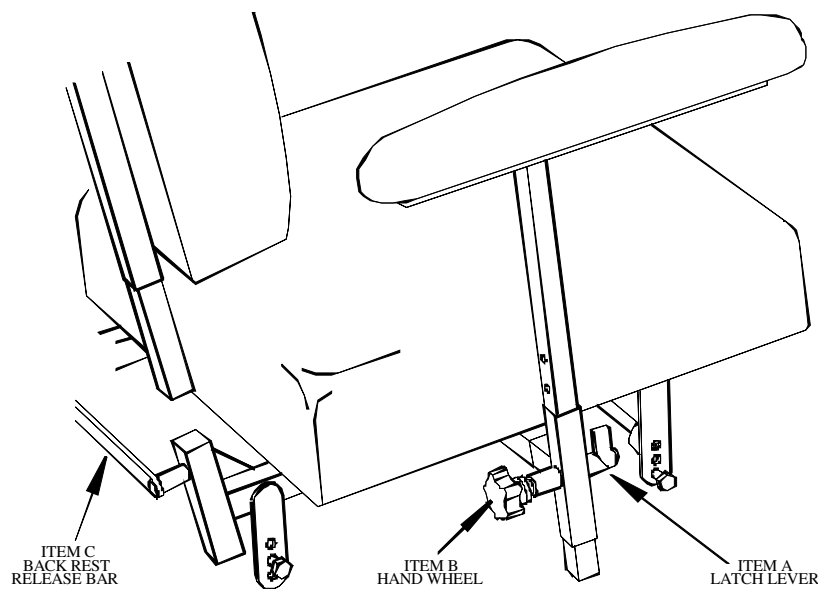

FIG.2.

Slide the armrest up or down to the required position and release the latch lever. Ensure that the latch lever is properly engaged in one of the location holes (the armrest will not move up or down). Then re-tighten the hand wheel. Tightening the hand wheel reduces 'free play' in the armrest. Tightening the hand wheel should only be used in conjunction with the latch lever. The hand wheel alone must not be relied upon to secure the armrest.

CAUTION. Take care to avoid pinching fingers during this operation.

2.2.2 REMOVAL OF ARMRESTS

Armrests can be removed from the seat unit to allow for 'side transfer' or to facilitate storage or transport.

To remove the armrest with the controller attached to it. First make sure that power to the wheelchair is turned off at the controller. Then remove the connector by holding the connector and pulling it out of the back of the controller (see figure 3).

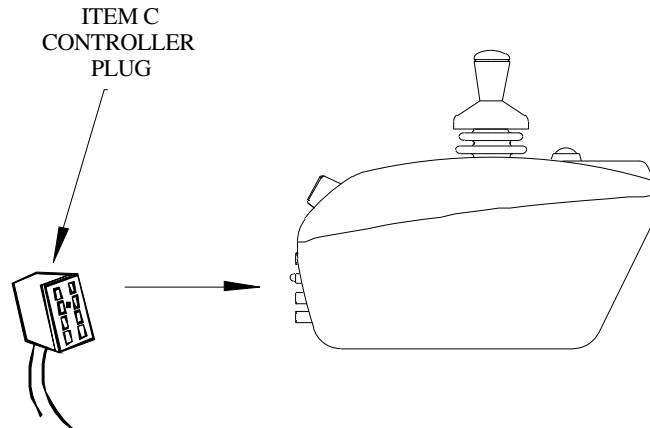

FIG.3.

Loosen the hand wheel and operate the latch lever as previously described (see figure 2). Lift the armrest out of its locating bracket and place it to one side, ready for storage or transport etc.

To remove the other armrest, repeat the above instruction.

CAUTION. Take care to avoid pinching fingers during this operation.

2.2.3 CONTROLLER MOUNTING BRACKET

The controller and mounting bracket are fitted to the specified armrest when dispatched. There should be no need to adjust the bracket. If you believe adjustment is necessary we recommend you contact your issuing authority.

2.3 REMOVAL AND FITTING OF BACKREST

The backrest can be removed to facilitate the transportation of the wheelchair.

2.3.1 REMOVING THE BACKREST

To remove the backrest pull the quick release bar (item C in figure 2) back from the wheelchair. Lift the backrest up until the backrest tubes have cleared the latch pins.

The quick release bar can then be released and the backrest removed and put to one side.

2.3.2 RE-FITTING THE BACKREST

To replace the backrest insert backrest tubes into the seat frame. Push the backrest down until the latch pins engage. Check that the quick release bar is fully re-engaged, and that the backrest cannot be lifted back out without having to operate the quick release bar.

2.4 REMOVING AND RE-FITTING THE SEAT UNIT

The seat unit can be removed to facilitate easier transportation or storage of the wheelchair.

2.4.1 REMOVING THE SEAT UNIT

Before you remove the seat unit you must disconnect the controller connector as described in 2.2.2 above. See figure 3.

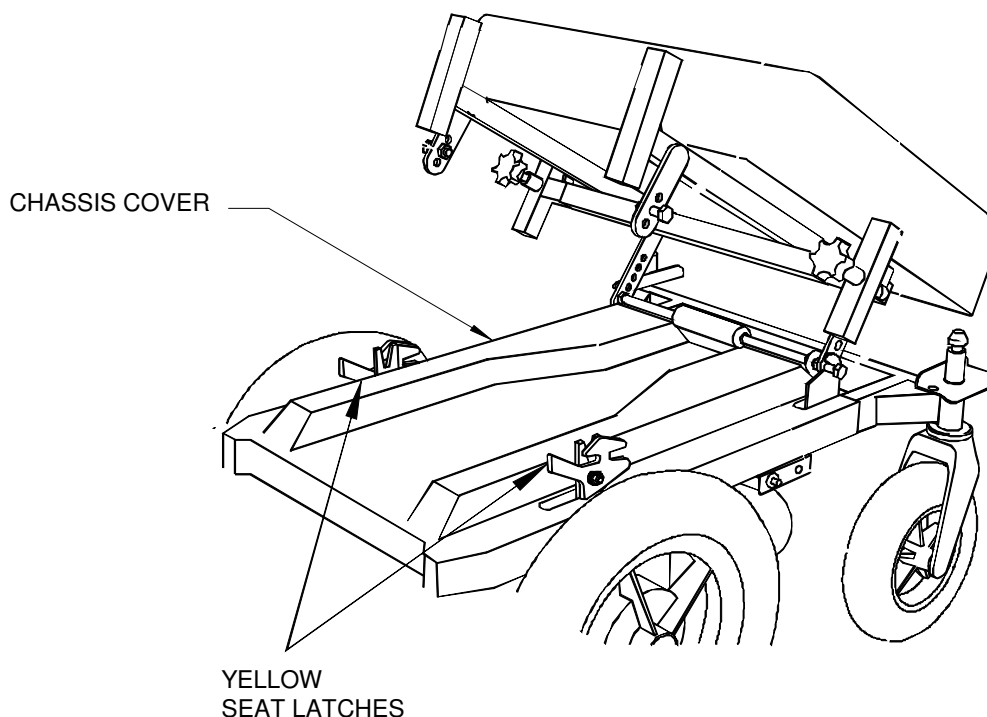

FIG.4.

To remove the seat unit, stand behind the wheelchair and simultaneously lift the 'yellow' seat latches on both sides of the wheelchair. Lift the seat free of the latches and pull the seat towards you until it clears the front mounting points. (See figure 4). Place the seat unit to one side ready for storage or transport etc.

2.4.2 RE-FITTING THE SEAT UNIT

Position the seat unit over the drive unit with the guide bar resting on the chassis cover.

With the seat tilted slightly forward, slide the seat unit forward until the seat bolts are located into the slots on the drive unit. (See figure 3). Ensure that the bolts have engaged properly. Lower the rear of the seat unit until the rear seat bolts engage the rear seat mountings and locks into position. Ensure that both seat latches have locked into position. Remember to reconnect the controller.

WARNING. Supplementary seat cushions must always be secured to the seat frame or baseboard.

NOTE. Removal and fitting of the seat unit can be made easier by first removing the armrests.

2.5 FOOTRESTS

The 'Vixen EPIOC' is equipped with swing aside footrests as standard.

2.5.1 REMOVING THE FOOTRESTS

To remove the footrest, raise the footplate to the upright position. Operate the latch lever item 'A' in figure 5, by moving it quarter of a turn until the latch pin is removed. Grasp the footrest bracket and turn it 90° outwards from the wheelchair then lift footrest up until it is clear of the mounting on the frame. Place the footrest to one side.

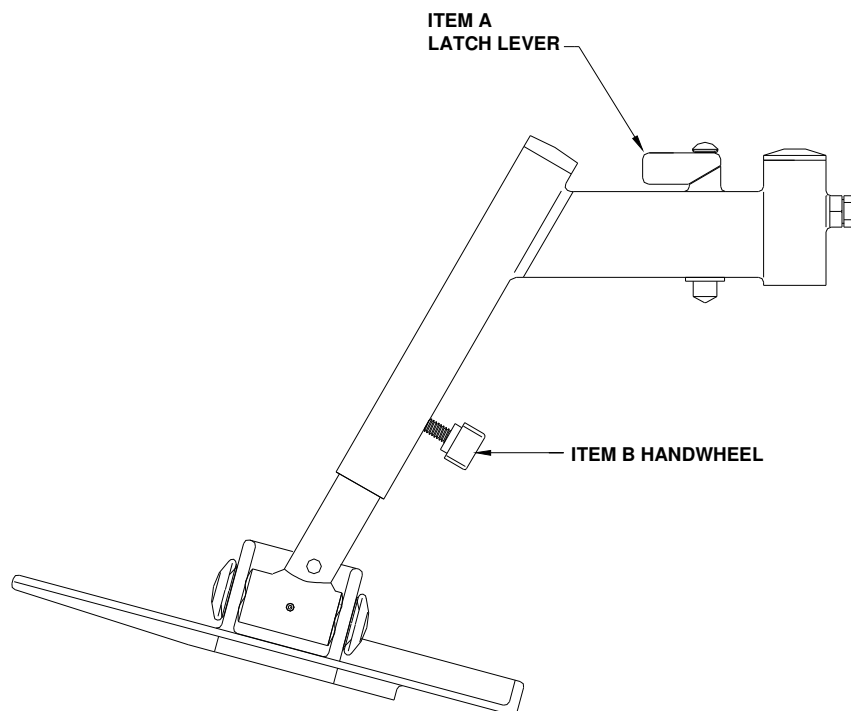

FIG.5.

2.5.2 RE-FITTING THE FOOTRESTS

To refit the footrests, operate the latch lever; item 'A' in figure 5. Locate the footrest above its mounting point at 90° to the wheelchair. Push the footrest down onto its mounting and turn it 90° forward ensuring that the latch lever returns to the locked position. Check that the footrest cannot be pulled off its mounting point. Push the footplate down to its open position. Repeat this operation for the other footrest.

2.5.3 ADJUSTMENT OF FOOTRESTS

Footrests can be adjusted vertically (up and down). They can be swung aside when the user is getting into or out of the wheelchair.

2.5.3.1 SWINGING ASIDE FOOTRESTS

To help ease transfer into and out of the wheelchair, the footrests can be swung aside. To swing the footrest aside, first lift the footrest plate into the upright position. Operate the latch lever 'item A' in figure 5 and rotate the footrest 180° until it points to the back of the wheelchair. Release the latch lever and ensure that the footrest is locked in position.

To return the footrest to the forward position. Operate the latch lever and rotate the footrest 180° to its forward position. Release the latch lever and ensure that the footrest is locked in the forward position. Push the footrest plate down to its stop ready for use.

CAUTION. Take care to avoid the risk of minor finger pinches when performing this task.

2.5.3.2 VERTICAL AJUSTMENT

To adjust the height of the standard footrest. Turn the handwheel 'item B' figure 5, anti-clockwise, until the footrest can be moved. Push up or pull down the footrest tube until the desired height is achieved. Retighten the hand wheel by turning it anti-clockwise. Check that when in use under load the footrest does not move. Repeat the adjustment for the other footrest.

NOTE. Your wheelchair will have been set up, using the settings considered to be the best for your needs at the time of prescription. You should maintain these settings. If you think the settings need to be reviewed you should contact the issuing authority

3. ANTI – TIP DEVICES

Anti – Tip devices are fitted to all wheelchairs in the ‘VIXEN’ range. See ‘item B’ in figure 6.

NOTE. The user must not attempt to adjust the anti tip devices.

Any necessary modification or adjustment will be considered during prescription and the work carried out by a competent person.

4. BRAKES

Each model in the ‘Vixen’ range is equipped with motor brakes and with a parking brake.

4.1 MOTOR BRAKES

Motor brakes known as electro-magnetic brakes are an integral part of each of your wheelchairs two motors. They operate automatically when the controller joystick is released (when the joystick is in the central position).

When the joystick is released there is a delay of approximately half a second before the brakes engage.

4.1.1 CHECKING OPERATION OF THE MOTOR BRAKES

As a matter of good safety practice you should check the operation of the electro-magnetic motor brakes each time you prepare to use your wheelchair.

With the freewheel device off (see 5.1) and the parking brake off (see 4.1.2) try to push the wheelchair pushing on each side in turn. If the electro-magnetic brakes are active the wheelchair will not move.

To check that the brakes function correctly. Switch on the power to the wheelchair and turn the speed control to low.

Move the joystick in any direction. The brakes should disengage (you will hear a click and the wheelchair should begin to move). Release the joystick and the brakes will re-engage (again you will hear a click), the wheelchair will stop and cannot be pushed. Repeat this check in all four directions (forward,back,left and right).

Ensuring that the brakes disengage when the joystick is operated and engage when the joystick is released. Always conduct this check on a level surface with sufficient room to avoid striking near by objects.

In the unlikely event of the brakes not working properly, immediately report the matter to the issuing authority. Do Not Use the Wheelchair until a competent person has examined it.

4.2 PARKING BRAKE

The parking brake is positioned at the rear of the wheelchair. It is foot operated and is intended for attendant use only. The parking brake operates directly on the wheel hub, providing positive locking of the drive wheels. They should only be used when the electric motors are disengaged. See Section Five Below.

The parking brake lever is situated between the rear wheels at the rear of the wheelchair. See 'item A' figure 6.

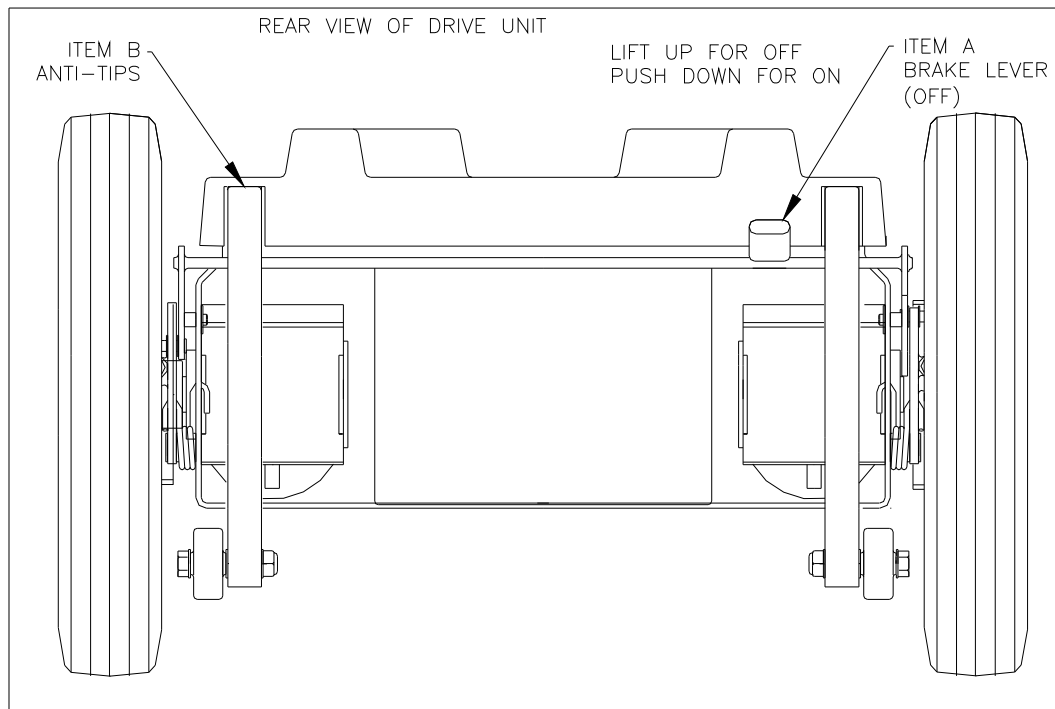

FIG.6.

5. FREE WHEEL DEVICE

Each model of 'Vixen' wheelchair is fitted with a free wheel device.

5.1 USING THE FREEWHEEL DEVICE

On each rear wheel there is a lever which operates the freewheel mechanism. See 'freewheel levers' figure 7.

Operating the freewheel mechanism allows an attendant to push the wheelchair with the motors disengaged, when the levers are in the 'Motor Off' position.

For the user to drive the wheelchair the levers must be in the 'Motor On' position.

To operate the freewheel mechanism pull out both the red levers and turn them to the 'Motor Of' position.

To re-engage the drive motors, turn both the red levers to the 'Motor On' position, being sure that both levers drop into their slot and engages.

WARNING. Never attempt to use the wheelchair with the motors disengaged.

Always before you use the wheelchair, check that both levers are in the 'Motor On' position.

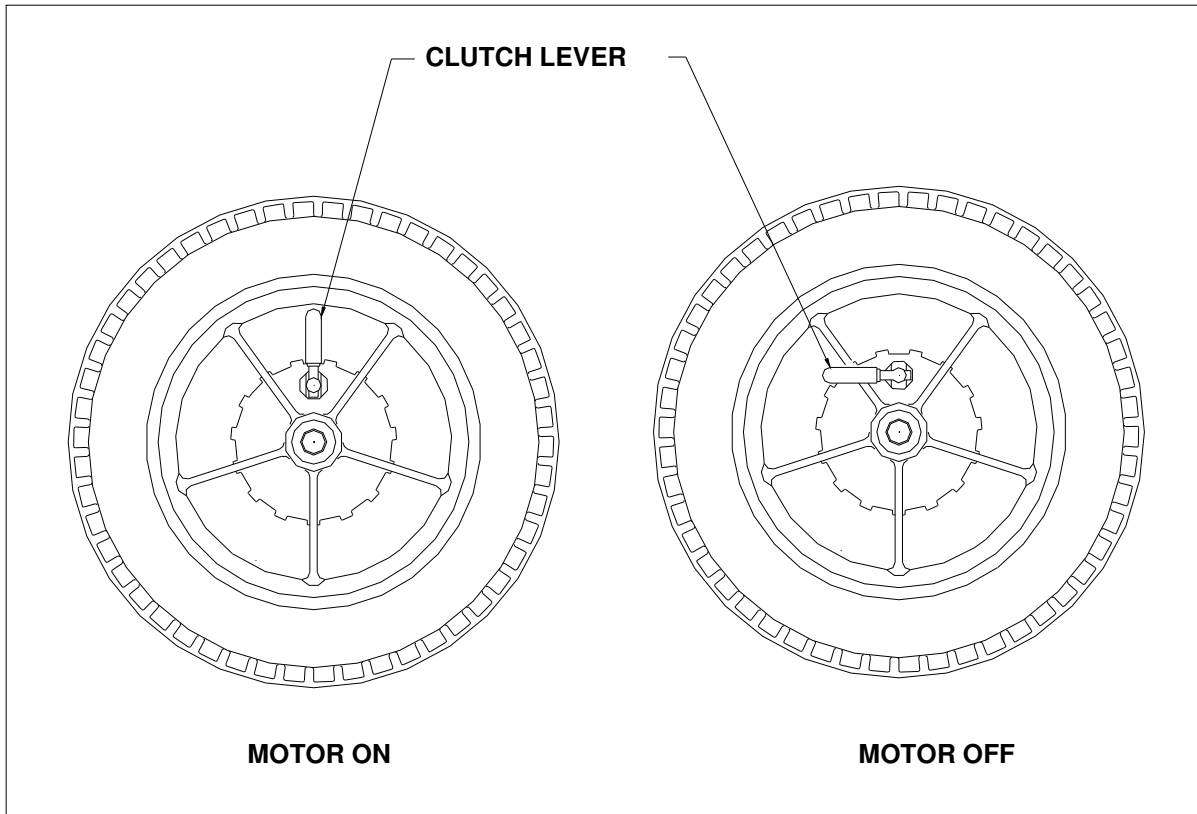

FIG.7.

6. KERB CLIMBING DEVICE

To allow you to mount kerbs when using your wheelchair a kerb-climbing device is fitted to your wheelchair. This device can be removed for transportation and storage purposes.

6.1 REMOVING THE KERB CLIMBER

To remove the kerb climber operate the latch lever shown in figure 1, by turning it 90°. Pull the kerb climber forward until it is clear of its location and release the latch lever. Store the kerb climber safely until it is required.

6.2 RE-FITTING THE KERB CLIMBER

IMPORTANT - Remember when re-fitting the kerb climber to ensure that you fit it with the toe pointing to rear of the wheelchair and its heel to the front of the wheelchair (See figure 1)

To re-fit the kerb climber operate the latch lever and line up the location pins with their location points on the frame. Push the kerb climber onto the wheelchair frame until the pins are fully located. Release the latch lever. Check that the kerb climber is locked in position by trying to pull it forward. If necessary repeat the above procedure to ensure it is properly located and locked in position.

In the unlikely event that it will not lock, do not attempt to make use of the kerb climber, report the failure to your issuing authority.

7. BATTERIES

WARNING. Risk of fire hazard and injury. Do not touch battery terminals. Never allow any metal objects to come into contact with the battery terminals. Connections to the battery terminals should be made by a competent person.

DO NOT smoke near batteries that are being charged

7.1 REMOVING BATTERIES FROM THE WHEELCHAIR

To remove the batteries from the wheelchair. Detach the controller plug (see fig. 3) Remove the seat unit and lift off the chassis cover (see fig. 4)

Disconnect the two battery connection plugs by firmly gripping the connector and pulling it up until it is clear from its socket, 'Item A' in figure 8.

The batteries can then be lifted out.

CAUTION. Do not try to disconnect the battery plugs by pulling on the wire

CAUTION the batteries are heavy. You should consider seeking help when they are to be lifted and moved.

7.2 REFITTING BATTERIES TO THE WHEELCHAIR

To refit the batteries reverse the procedure given in 7.1.

CAUTION. Ensure that connector plugs are properly orientated and fully pushed home. Do not force them. Report any connection problems to your issuing authority.

NOTE batteries are positioned with their positive terminal (+) towards the front of the wheelchair.

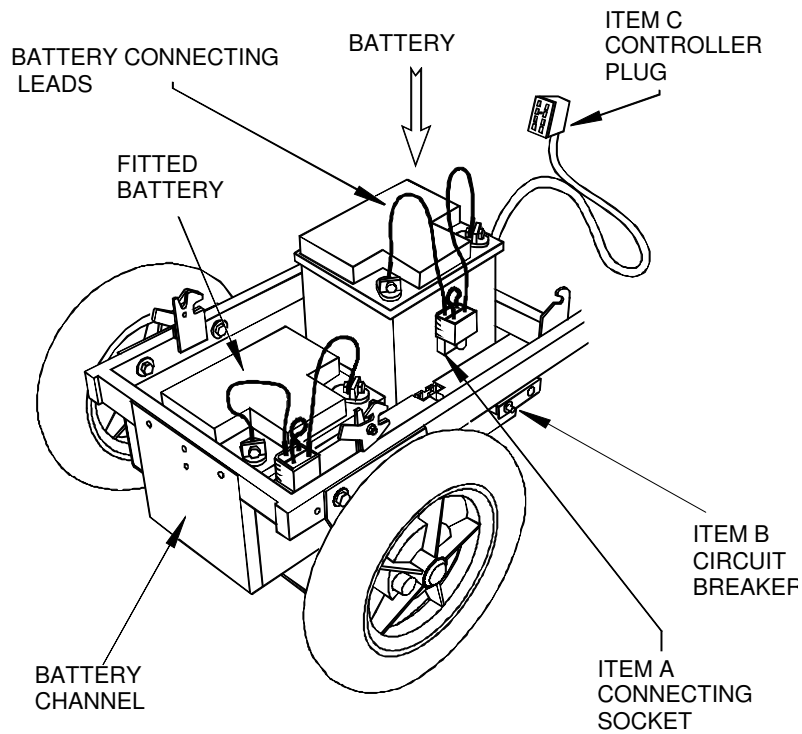

FIG.8.

7.3 THE BATTERY CHARGER

A battery charger is supplied with your wheelchair and will have a plug fitted for connecting your charger to the mains electricity supply.

The charger also has a plug fitted to connect your charger to your wheelchair controller. See 'Item A' in figure 9.

The model charger supplied by your issuing authority may vary. However, it is standard that most chargers will have 'red' power on, 'Orange' charging taking place, and 'green' charging complete lights.

NOTE. See the charger front panel and charger manufacturers instructions for your particular charger for more details.

7.4 CHARGING THE BATTERIES

NOTE it is important to follow these instructions for a complete charge cycle.

1. Check that the ventilation slots on the charger are not obstructed.
2. Check that the wheelchair is turned off.

3. Connect the charger output plug, 'Item A' in figure 9, to the wheelchair charger socket. See figure 10.

CAUTION. Ensure that the charger controller plug (item A) is properly orientated and fully pushed home. Do not force the plug in. Report connection problems.

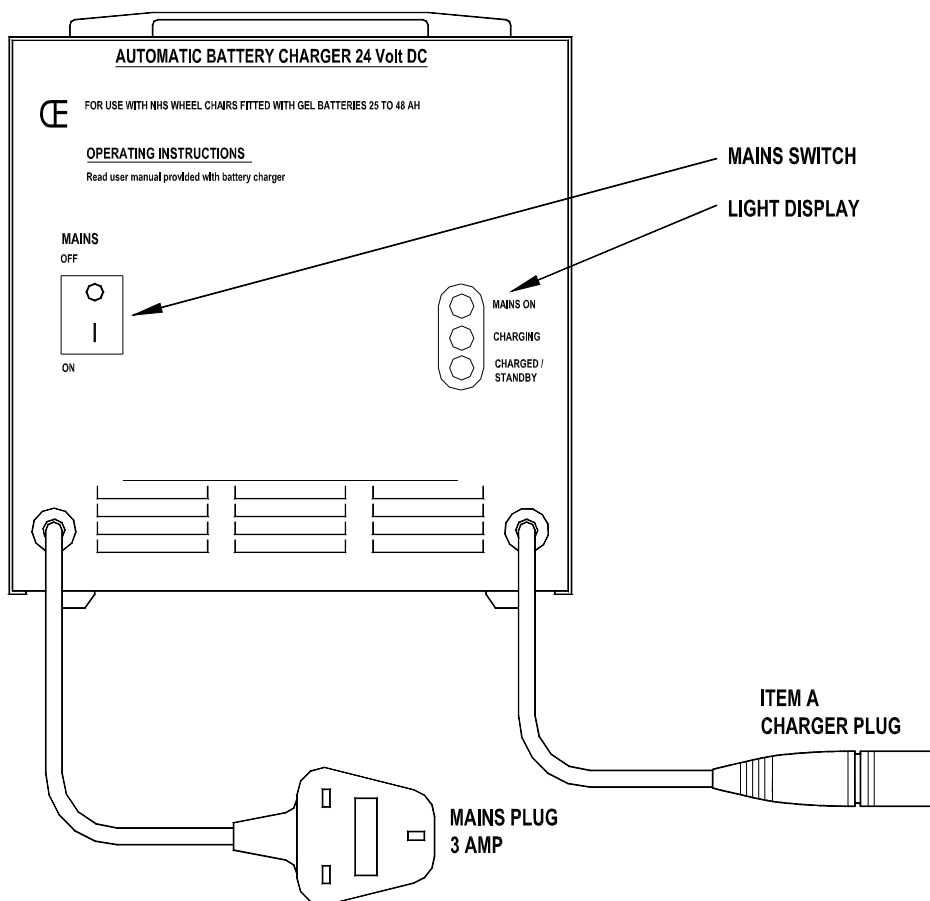

FIG.9.

4. Connect the charger to the mains electricity supply and switch the mains supply at the socket. Switch on the battery charger. The 'Red' mains on light and the 'Yellow' charging lights will illuminate.

CAUTION. Ensure that the mains plug is fully pushed home when connecting the mains supply. If the plug becomes damaged or becomes hot when in use, do not use, turn off at the mains switch and report the matter to your issuing authority.

NOTE. The charging cycle may take up to 12 hours.

5. When the 'Green' charge complete light illuminates the batteries are fully charged.
6. Always switch off the mains electricity supply socket before removing the charger plug from the wheelchair.
7. Do not attempt to move the wheelchair until the battery charger has been disconnected.
8. The charger may be left connected to the wheelchair/batteries with the mains supply switched on for up to 24 hours. This will ensure that the batteries are held in a fully charged condition.
9. Do not leave the charger connected to the wheelchair/batteries with the mains supply switched off. As this will slowly discharge the batteries.
10. When the wheelchair has been left unused for over one month a top up charge is recommended before it is used. To do that, follow the above procedure for charging.

NOTE. Batteries fitted to your wheelchair are sealed and no maintenance is required. Any attempts to open the vents will damage the battery and is dangerous.

NOTE. The charger supplied with the wheelchair is designed specifically for use with maintenance free batteries

CAUTION

Do Not Allow any charger to be used with your batteries, that has not been supplied to you by the issuing authority. Using the wrong charger can permanently damage your batteries.

Do Not use the charger out of doors. It is for indoor use only.

Do Not use near a bath, shower, sink or any other source of moisture that could enter the charging system.

Do Not smoke near the batteries when charging.

Do Not expose the charger to external heat sources such as radiators, fires and direct sunlight.

Do Not try to move the wheelchair until the battery charger has been disconnected from the mains supply and from the wheelchair.

Do Not switch on the wheelchair control box with the charger connected as this will register as a fault on the controller.

Do Not force connectors or plugs 'in', report problem if plugs do not fit.

Do Not attempt to disconnect plugs or connectors by pulling on their wires or cables.

Report any malfunction of your charger to your issuing authority.

7.5 BATTERY USE – BEST PRACTICE

Always observe the following points concerning use of your wheelchair. Doing so will help you obtain good service from your wheelchair.

1. For an active person (one who uses their wheelchair a lot every day). Charge your batteries to a daily routine. Ideally you should do this when the battery gauge on your controller shows red and yellow bars lit. When only red bars are lit or slowly flash, the batteries should be charged before the wheelchair is used further.
2. For a less active user. Charge once or twice a week. Ideally you should do this when the battery gauge on your controller shows red and yellow bars lit. When only red bars are lit or slowly flash, the batteries should be charged before the wheelchair is further used.
3. If you store your batteries. Store them fully charged and recharge them once a month.
4. Battery failure. If you have followed the above procedures and find that your batteries have failed or do not give proper service. You should contact your service contractor/issuing authority, which will arrange to have your batteries checked and replaced if necessary. They will also arrange for the proper disposal of old batteries issued by them.

8. CONTROLLERS

Your wheelchair is fitted with a state of the art electrical controller. The option fitted will have been chosen by your issuing authority to best suit your needs.

All controllers are factory set to give optimum performance for all conditions. Should the operating parameters need to be changed for a medical/prescription reason, the safety implications for the user will be considered by a competent person and any necessary adjustments carried out.

Caution. The electronic circuit and the controller of your wheelchair have been designed with your needs and safety in mind. Do not attempt to alter it in any way or try to open the controller. In the unlikely event of a malfunction which you cannot rectify by following the manufacturers user instructions. Stop using the wheelchair and immediately report the problem to your issuing authority.

Details of the controller fitted to your wheelchair are given below.
See 8.1.

8.1 YOUR CONTROLLER

Your wheelchair is fitted with a Penny and Giles 'Pilot' controller.

8.1.1 IMPORTANT : PRECAUTIONS FOR USE

The Pilot controller has been designed with the user's safety as the prime consideration.

However, in spite of its sophistication, the controller cannot take into account circumstances which put the wheelchair or the controller outside of their specified operating conditions, and so it is important that the user follows the precautions below:

- 1) Do not drive the wheelchair:
 - a) Beyond restrictions indicated in this user manual, for example maximum inclines, etc.
 - b) In places or on surfaces where a loss of wheel grip could be hazardous, for example on wet slopes such as wooden ramps.
 - c) If the controller or other crucial components are known to require repair.

In the event of the wheelchair moving in an unexpected way **release the joystick.**

This action will stop the wheelchair under any circumstances.

2) Although the Pilot controller is designed and manufactured to be extremely reliable, and each unit rigorously tested, the possibility of a system malfunction always exists (however small the probability). Under some conditions of detected system malfunction, the controller must (for safety reasons) stop the chair instantaneously. If your physical impairments are such that a sudden braking action could result in a fall from the chair, it is imperative that a posture device such as a seat belt is installed with the chair. This will be considered at the time of prescription. Where fitted these devices should be used at all times when the wheelchair is in motion.

3) Under strenuous driving conditions it is possible for the bottom and side case temperature of the Pilot controller to exceed 41°C. The user should not touch the side or bottom of the controller under these circumstances.

Pilot Integral Controller

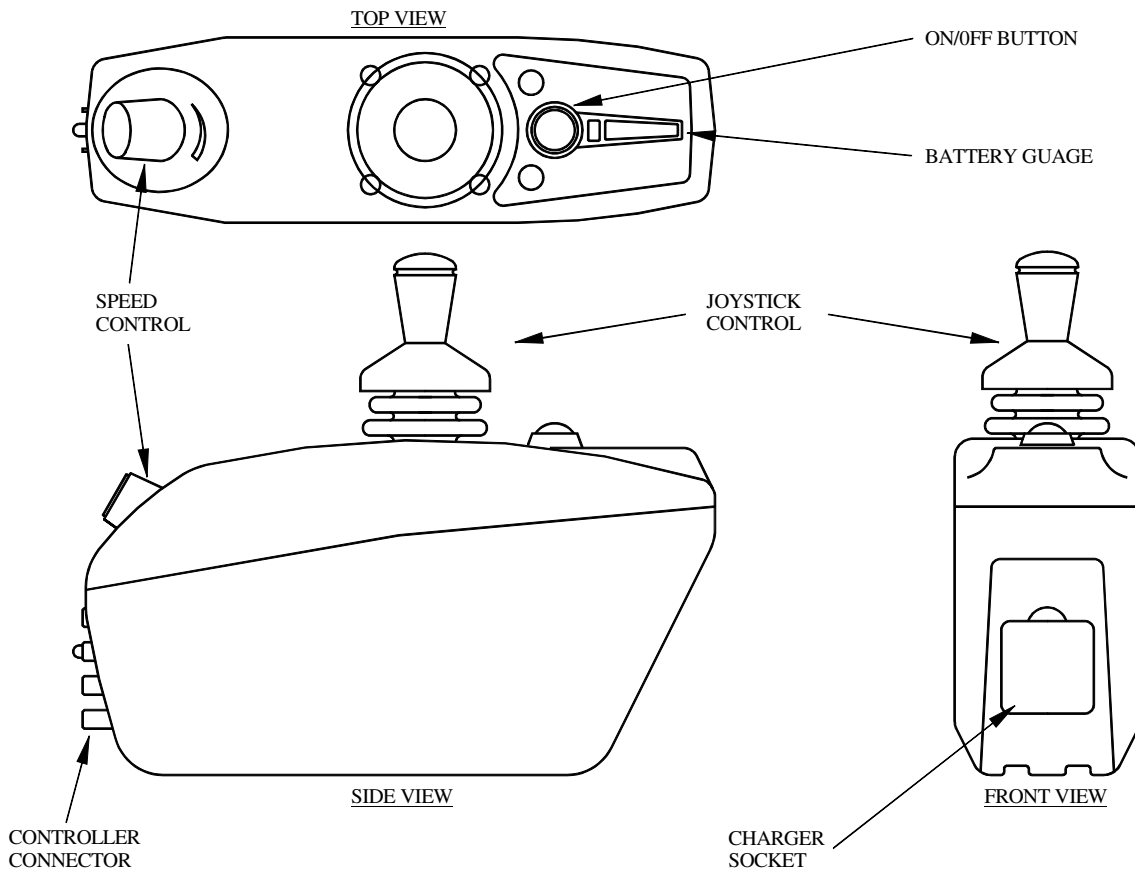

FIG.10.

8.1.2 CONTROLS

On/Off Pushbutton

This is a green pushbutton switch fitted in front of the joystick which turns the controller on and off. **Do not** use this switch to stop the wheelchair except in an emergency. See figure 10.

TruCharge Battery Gauge

This is a 10 segment illuminated display which indicates if the controller is turned on and also gives the status of the battery, the controller and the wheelchair electrical system. See figure 10.

Red, yellow and green bars lit: Battery charged; controller and electrical system OK.

Red and yellow bars lit: Charge battery if possible; controller and electrical system OK.

Red bars only lit or slow flash: Charge battery as soon as possible; controller and electrical system OK.

Rapid flash of bars: Indicates a fault in the controller or electrical system. Refer to faultfinding documentation.

Ripple up and down of bars: Joystick displaced at turn on. Where this happens release the joystick, turn off controller. Then turn controller back on without touching the joystick

Joystick

Controls the speed and direction of the wheelchair. Push the joystick in the direction you wish to go. The further you push it, the faster the speed. Releasing the joystick stops the wheelchair automatically. See figure 10.

Speed Control

Sets the maximum speed of the wheelchair: turn clockwise to increase the speed, anti-clockwise to decrease. See figure 10.

AVOID knocking your controller, especially the joystick. When transporting your wheelchair ensure the controller is well protected.

9. USING THE WHEELCHAIR

Your wheelchair is an Electrically Powered Indoor Outdoor Wheelchair (EPIOC).

9.1 INTENDED USE

It is designed and intended for both indoor and outdoor use.

Before use out of doors, a little time spent planning your trip can be of benefit, by helping you avoid routes that are difficult and involve a lot of kerb climbing, or obstacles that you may find difficult to negotiate.

Your wheelchair is not suitable for general 'off road' use out of doors. You must avoid trying to use your wheelchair on soft ground such as wet earth and grass, deep gravel paths and sand etc.

9.2 GETTING INTO THE WHEELCHAIR

For your maximum safety, and depending on your capability, you should consider carrying out the following operation with the help of an attendant. The occupant should try to assist the attendant, by sharing the total effort required.

Make sure that the power to the wheelchair is turned off and that the brakes have been activated.

Raise the footrests into the upright (vertical) position.

Stand in front of the wheelchair, between the footrests and facing forward, away from the wheelchair. Hold the armrests as support whilst lowering your self to the sitting position in the chair. Adjust to a comfortable position in the seat. Then lower the footrests to the horizontal position and place your feet on the footrests. Obtain assistance from an attendant if necessary.

CAUTION. Do not attempt to stand up on the footrests or use them as a step to get into or out of the wheelchair.

WARNING, TRIP HAZARD. If your wheelchair is fitted with a kerb climber, take care when entering or leaving the chair, it may be better to remove it when not in use.

Side transfer into the wheelchair is possible, using an appropriate side transfer board. Before side transfer the footrest and armrest from the side into which you want to transfer should be removed before side transferring and refitted after your transfer is complete.

CAUTION. Only attempt side transfer using appropriate equipment after you have been given instruction.

CAUTION. Avoid transferring into or out of your wheelchair on wet or slippery surfaces.

9.3 GETTING OUT OF THE WHEELCHAIR

For your maximum safety, and depending on your capability you should consider carrying out the following operation with the help of an attendant. The occupant should however, try to assist the attendant, by sharing the total effort required.

Make sure that the brakes are activated and that the power to the wheelchair is turned off. You can then transfer out of the wheelchair using the reverse of either of the methods described in 9.2 above.

9.4 DRIVING THE WHEELCHAIR

You will also need to consider the distance you want to travel and the range your wheelchair can travel. Remember it is better to start a trip with fully charged batteries. The range will be affected by the load it is carrying, and the terrain it has to travel over.

When planning your trip, remember that it takes more battery power to go uphill than it does to go down. Each hill you go down on the outward journey has to be climbed on the return journey.

Your wheelchair is not intended for general use on the highway. You should always use the pavement wherever possible. When crossing the highway always use a designated pedestrian crossing if one is available.

Most urban areas now have wheelchair friendly crossing points (dropped kerbs) that allow you to move from or to the pavement without the need to use your kerb climber. Obstacles you encounter that present difficulties to you, e.g. a blocked pavement, broken paving or lack of wheelchair friendly crossing points can be reported to your local authority.

When using your wheelchair out of doors in poor visibility you should wear clothing that allows you to be visible especially where you have to cross over the highway. It is recommended that you wear a reflective bib such as those worn by cyclists.

When travelling on the pavement, always remember that many pedestrians may not hear you approaching and can not move as fast as you can in your wheelchair. Always give consideration to pedestrians and adjust your speed as appropriate.

Your needs as a user will be discussed with you when your wheelchair is being prescribed. If you consider that your wheelchair is unsuitable for your needs you should contact your issuing authority.

CAUTION. You should not attempt to use your wheelchair for other than its intended purpose or outside the instructions given in this user guide.

A little thought planning your journey before using your wheelchair can help make its use a more satisfying and safe experience. Avoiding unnecessary obstacles and risks.

To drive your wheelchair, turn on the power by pressing the power on button. Set the speed controller. You should set this to a slow speed until you are fully familiar with your wheelchairs performance characteristics.

Move the joystick in the direction in which you need to travel. Adjust your direction of travel by moving the joystick in the direction you want to travel in.

As you become more confident, you can adjust the speed setting to suit your needs.

To stop in an emergency just release your joy stick and the automatic brake will activate.

9.5 NEGOTIATING OBSTACLES

Your wheelchair is designed for outdoor use and is equipped with a kerb-climbing device, which is attached to the front of the wheelchair. The kerb-climbing device operates automatically where needed. It will operate to help you climb a kerb that is more than 40mm (1.5") high.

9.5.1 CLIMBING SMALL KERBS - UNDER 40mm HIGH

Climbing kerbs under 40mm high does not activate the kerb-climbing device as small kerbs can be climbed without it.

NOTE. You must still exercise caution when climbing small kerbs (transitions).

9.5.1.1 TO CLIMB A SMALL KERB

Set the speed control to slow. Approach the kerb straight on in a forward direction at an angle of 90°. Drive straight forward up the kerb until the rear wheels have also climbed the kerb. Adjust your speed control for your desired speed. Then if the way is clear, drive away forward in your chosen direction.

9.5.1.2 TO DESCEND A SMALL KERB

Approach the kerb backwards and square on at an angle of 90°. Check that the route behind you is clear. Set your speed control to slow. Drive backwards until all wheels have descended the kerb. Stop, and then adjust speed control for your desired speed. Then if the way is clear, drive away forward in your chosen direction.

9.5.2 CLIMBING KERBS - OVER 40mm HIGH

The kerb-climbing device will operate automatically when required. You must follow the instructions given. If you do not feel confident enough to carry out this manoeuvre, you should seek further advice or training from your issuing authority.

CAUTION. Kerb climbing and descending requires practice in order to become proficient. Practicing under the supervision of a carer may help improve your ability and confidence. However, you should guard against over confidence and taking unnecessary risks.

CAUTION. The maximum kerb height your wheelchair is intended to climb is 75mm (3"). Do not climb kerbs higher than 75mm (3").

CAUTION. Kerb climbing and descending requires practice in order to become proficient. Practicing under the supervision of a carer may help improve your ability and confidence. However, you should guard against over confidence and taking unnecessary risks.

CAUTION. Never drive at full speed from a distance off to climb or descend a kerb.

CAUTION. Do not attempt to ascend or descend a kerb when travelling across a slope.

NOTE. With a little planning and thought many obstacles such as kerbs can be avoided.

9.5.2.1 CLIMBING A KERB

Look ahead to ensure that you have at least 2 metres (just over 2 yards) of clear pavement width in front of you after the kerb.

Look around and ensure that you are not at risk from traffic etc.

Approach the kerb square on, perpendicular to the kerb (each castor wheel being an equal distance from the kerb).

Stop the wheelchair when the footplates are almost at the kerb.

Adjust your speed control to full speed.

Push the joystick forward fully forward to climb the kerb. Avoid sideways movement of the joystick when doing this.

Release the joystick as soon as the rear wheels of your wheelchair have mounted the kerb.

Adjust the speed setting to your requirement and so long as the way is clear drive off in you're chosen direction.

9.5.2.2 DESCENDING A KERB

Kerbs must be descended travelling in the backward direction. Descending kerbs in a forward direction can cause you castor wheels to lock and your wheelchair to tip forward, putting you at risk. You can also cause permanent damage to your castor wheels.

Approach the kerb with the rear wheels square on to the kerb.

Set your speed control to its lowest setting.

Check behind you to ensure that the way is clear and that it is safe to proceed.

Pull the joystick backwards just enough to slowly drive the rear wheels down over the kerb. Maintain the joystick in this position until the castor wheels have descended and are clear of the kerb.

Adjust the speed setting to your requirement and so long as the way is clear drive off in you're chosen direction.

9.5.2.3 USING THE WHEELCHAIR ON SLOPES

CAUTION. Slopes of more than 18% (10°) are steep slopes. They will not normally be encountered.

NOTE. You should not use your wheelchair on slopes greater than 18% (10°). If you believe that you cannot avoid such steep slopes you should bring this to the attention of your issuing authority.

9.5.3.1 TO GO UP A SLOPE

Stop a metre before the slope at 90° (square on to) the slope. Set your speed control to approximately half speed. Drive forward slowly up the slope. Leaning slightly forward will add to your stability. Avoid sudden stops and starts on the slope.

9.5.3.2 TO GO DOWN A SLOPE

Stop a metre before the slope at 90° (square on to) the slope. Set your speed control to slow speed. Drive forward slowly down the slope. Leaning back in the wheelchair will add to your stability. Avoid sudden stops and starts on the slope.

NOTE. Slopes of under 10% (6°) pose less risk of instability and tipping. However, care should always be exercised. It is always best to avoid starting or stopping suddenly on a slope. Crossing roads, pavements or other terrain on slopes is best avoided. Do not attempt to cross slopes of more than 6°.

9.5.3.3 GOING ACROSS A SLOPE

To travel across (traverse) a slope set your speed to a slow speed. Driving slowly across the slope will give you more control and help avoid your wheelchair sliding down the slope. Having crossed the slope, set your speed control for the desired speed, and if the way is clear drive off in your chosen direction.

CAUTION. Always seek the assistance of an attendant or carer unless you are confident of carrying out any manoeuvre on your own.

If you regularly encounter access problems with your wheelchair, you should contact your issuing authority.

10. TRANSPORTING THE WHEELCHAIR

The 'Vixens' modular design allows easy dismantling of the wheelchair, without the need to use tools. Depending on the size and shape of your vehicle luggage compartment, your wheelchair can be dismantled to be transported in the luggage compartment. The wheelchair will fit into the luggage compartments of most small cars e.g. Ford Fiesta, Peugeot 104, Rover Metro, etc.

Dismantle the wheelchair for loading by:

Disconnect the controller. See 2.2.2

Remove the armrests. See 2.2.2

Remove the backrest. See 2.3.1

Remove seat unit. See 2.4.1

Remove footrests. See 2.5.1

Remove battery compartment cover.

Remove batteries. See 7.1

Load the chassis into the vehicle.

Replace the batteries (but do not reconnect)

Replace the battery cover.

Load the other component parts.

At your destination unload the components and assemble the wheelchair following previous instructions.

The free wheel devices can be used to move and position the wheelchair when this is being done. See 5.1

Check that all connections are properly made and that power is available.

Check the electromagnetic brake function before using the wheelchair.

10.1 USING LOADING RAMPS

Particularly where the user has an estate car. The loading of the wheelchair can be made easier by using trough ramps. If you wish to consider the use of loading ramps, you should seek advice regarding options, availability and cost. They are normally not provided by your issuing authority.

11. USING THE WHEELCHAIR IN A VEHICLE

Many thousands of journeys in wheelchairs transported in vehicles are made each day safely and without mishap. Reading and following these instructions will help ensure your safety.

Wherever possible it is recommended that wheelchair occupant transfer to a vehicle seat during a journey and that they use the seat belt that is provided. The wheelchair can then be securely stored in a designated storage area and secured for the journey.

Public transport buses and trains, increasingly offer designated areas that can be used by persons travelling in their wheelchairs. Where these facilities exist, they should be used in accordance with and observing all instructions given.

Specialized transport for wheelchair occupants is provided by ambulances and community transport buses. These vehicles should be fitted with approved anchorage and tie down systems.

Fittings such as trays should be removed for transport and stored separately. Fittings that can not be removed should be subject to risk assessment by your issuing authority.

The inertia belt provided in the vehicle must be used as your personal restraint.

You must not depend upon chest and lap; posture belts alone to retain you in your wheelchair during transportation. See 11.1.3 below.

Please ensure that your wheelchair is secured in the vehicle as described below, before allowing your self to be transported.

11.1 VIXEN EPIOC WHEELCHAIR - RESTRAINT INSTRUCTIONS

11.1.1 WHAT YOU SHOULD KNOW BEFORE ENTERING A VEHICLE-

(A) Confirm that the vehicle in which you are about to travel has been designed and equipped to transport a passenger seated in a wheelchair in safety.

Confirm that your Newton Vixen wheelchair has been designed and equipped to be restrained in a vehicle. (See instruction B 1)

(B) It is imperative that the wheelchair is correctly restrained and you are also correctly restrained and that any accessories or other loose items are stowed separately and safely elsewhere in the vehicle.

11.1.2 WHAT YOU SHOULD KNOW FOR A SAFE RESTRAINT PROCEDURE

(A) Always use an approved Newton wheelchair with a 'CRASH TESTED' label on the front and rear of the battery compartment.

Further Identification is confirmed where anchor point labels are affixed to the front of the chassis and rear seat latches are painted yellow.

Note Products must have all of the above features to be transport approved.

(B) The wheelchair must be forward facing in the vehicle

(C) Wheelchair Restraint.

Newton Products Ltd, recommend:-

Unwin 'Karabiner Heavy Duty 4-point Webbing Wheelchair Restraint':-

Ref. WWR / HD / ATF / K / R (heavy duty Karabiner, identified by a silver finish)

Any other system must be fully risk assessed by the issuing authority and transport provider before it is used.

The wheelchair is clearly marked at the points where the restraint is fixed with a yellow seat latch plate at the rear and yellow marker labels at the front of the wheelchair chassis.

Under no circumstances must you use any other fixing point on the chair.

(D) Passenger Restraint

Newton Products Ltd, recommend either :-

Unwin 3 point occupant restraint with double inertia reel:-

Ref. ATF, 3pt QIR / 3H / ATF / FA / WH

Or

Koller 3 point occupant restraint with double inertia reel:-

Ref. KFP0031

Any other system must be fully risk assessed by the issuing authority and transport provider before it is used.

11.1.3 OTHER IMPORTANT CONSIDERATIONS

Do not allow yourself, under any circumstances, to be restrained directly to the wheelchair. Should it be necessary to use other harnesses for clinical needs, then a Senior Rehabilitation Engineer should establish whether these restraints have been approved for use in combination with standard 3-point occupant restraint systems, and are safe to use, and have sufficient 'give' to allow the Passenger Restraint system to function correctly. **FINALLY YOU MUST UNDERSTAND THAT NO TIE DOWN SYSTEM WILL PROVIDE THE SAME LEVEL OF SAFETY AS THE SEATING DESIGNED FOR THE VEHICLE IN WHICH YOU ARE TRAVELLING. IT IS ADVISABLE THEREFORE TO TRANSFER TO STANDARD VEHICLE SEATING SYSTEMS WHENEVER POSSIBLE.**

11.1.4 SECURING YOUR WHEELCHAIR IN A VEHICLE

Please read the manufacturers Restraint Instructions before you begin.

- (A) Position the wheelchair over the rails and apply the foot-operated brakes.
- (B) Attach front restraints to the rail so that the buckles 'press' point outwards.
- (C) EPIOC Model (see Fig. 11).
- (D) Take the harness tongue over the front frame tube, then down and behind the castor mounting, under the side frame tube and forwards before securing into the buckle. Repeat for the other side.
- (E) Attach the rear karabiners to the Restraint/Seat Mount (indicated by the yellow seat latch), with the karabiner latch opening pointing outwards.
- (F) Ensure that the karabiner is registered in the slot provided. (See Fig. 12)
- (G) Follow manufacturers Restraint Instructions to finish securing the wheelchair.
- (H) Apply the passenger restraint (inertia belt)
- (I) Reverse above procedure to release the wheelchair.

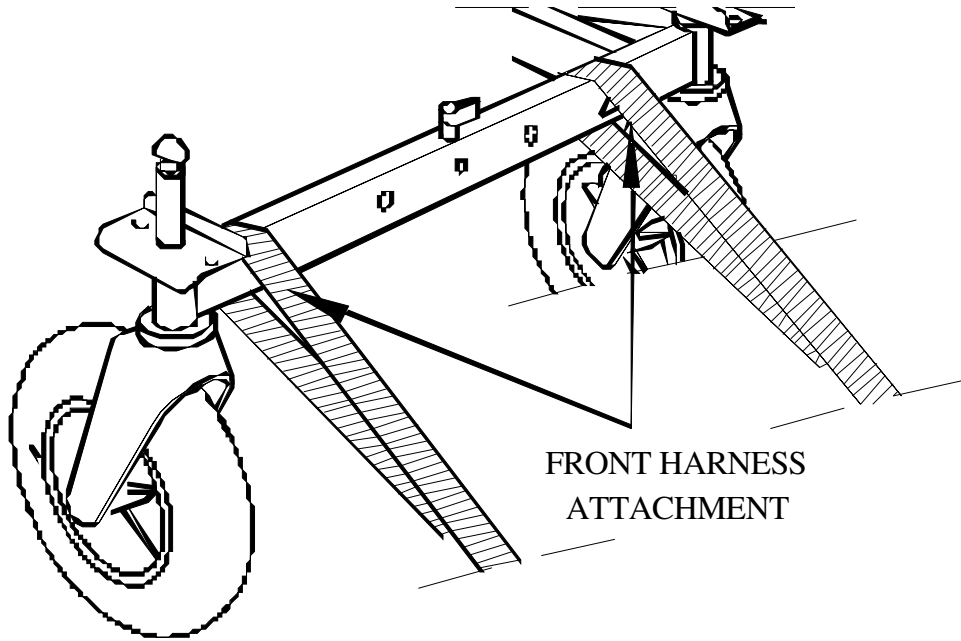

FIG .11.

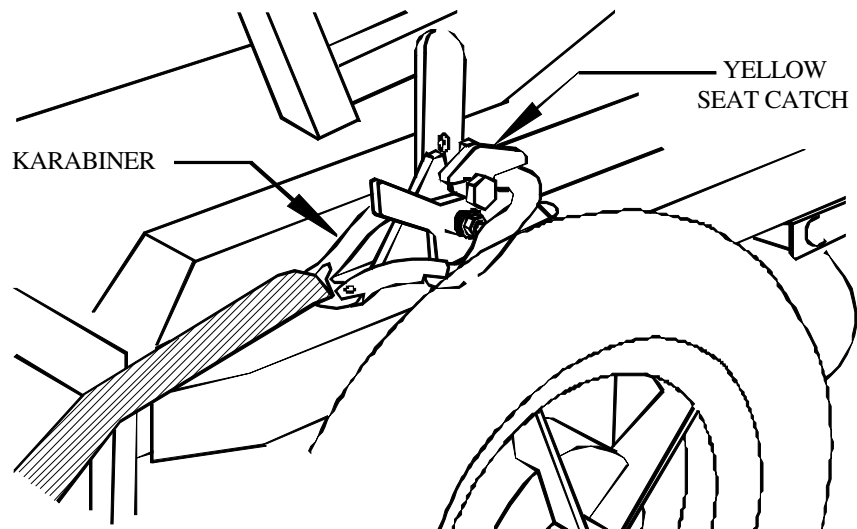

FIG 12

12. OTHER SAFETY ADVICE

Please observe the following additional safety precautions when using your wheelchair.

12.1 FIRE PRECAUTIONS

Disabled persons are at greater risk than others in the event of a fire. When using the wheelchair, always be aware of your wheelchair location and the proximity of fire exits.

Do not park your wheelchair too close to an open fire or intense heat source, even if unoccupied.

Your wheelchair upholstery meets the required standards for fire retardancy. However, smokers' materials can still pose a danger, particularly to clothing and covers etc and great caution should be exercised. If possible you should refrain from smoking whilst using your wheelchair.

If transporting your wheelchair in the luggage compartment of your car. Remember that during hot weather component parts could become hot to handle. Covering the wheelchair parts during transportation will help avoid this.

12.2 MOBILE TELEPHONES

Wheelchair users and attendants need to be aware of the safety issues surrounding the use of mobile communications such as mobile phones and sensor technology.

The performance of your wheelchair can be influenced by electromagnetic fields such as those emitted by mobile phones.

Before using a mobile phone you should stop your wheelchair and turn off its power.

12.3 OTHER SAFETY WARNINGS

Do not allow anyone else to use your wheelchair.

Do not carry children with you in your wheelchair

Do not allow children to play with the wheelchair.

Do not allow any unauthorized person to attempt to modify, or carry out unauthorized repairs on your wheelchair.

Do ensure that you are familiar with your user instructions and that they are kept safe and referred to as necessary.

Do carry out all user safety checks as are given in the user instructions.

Do maintain your wheelchair as recommended.

Do report promptly to your issuing authority any failure, breakage or malfunction.

13. ACTION TO BE TAKEN BY USER IN EVENT OF A WHEELCHAIR FAILURE OR AN ACCIDENT

In the event of an accident with your wheelchair in particular where it was being used by you in a vehicle. The accident should be reported to your issuing authority in order that they can examine the wheelchair. So as to ensure that there is no hidden damage which may effect its safe use. And that any failure can be investigated and necessary repairs carried out.

14. CARING FOR YOUR WHEELCHAIR

User maintenance requirements are limited to, cleaning, battery charging, tyre pressure (where pneumatic tyres are fitted) and condition checks, and visual checks of controller connections and general condition of the wheelchair.

14.1 DAILY CARE

Electrical brakes. Check operation before using wheelchair. See 4.1.1 above

Connections To Controller. Check that connector is not damaged and that it is fully connected to the controller (pushed right in not loose)

Mounting. Make sure that the controller is securely fixed to your wheelchair.

Joystick. With controller switched off, check that joystick is not bent and that it returns to its centre position when released.

Batteries. Check state of battery charge using 'True Charge Battery Gauge' on the wheelchair controller. Charge if necessary. See 6.3 above.

14.2 WEEKLY CARE

Cleaning. Clean the upholstery using a damp cloth. Dampen the cloth with some water to which some soap such as washing up liquid has been added.

Do not apply water directly to your wheelchair and never allow your wheelchair to be washed down using a hosepipe or other copious source of water.

Chrome and painted surfaces can be cleaned using a dry soft cloth. For clinging dirt first use a damp cloth as described above.

Controller. If your controller has become contaminated with food or other dirt, it should be cleaned using a damp cloth. Turn off the controller before you clean it.

14.3 MONTHLY CARE

Tyres. Check general condition of tyres for gouges or bald patches of tread. Where pneumatic tyres are fitted, check the tyre pressures at least once a month. They should be inflated to 250 Kpa (36 p.s.i).

General Condition Of Wheelchair. Look at your wheelchair for any sign of structural damage. In the unlikely event of such damage being discovered, it should be immediately reported to your issuing authority.

14.4 SERVICE AND MAINTENANCE

Apart from the tasks described above all other service and maintenance will be provided by your issuing authority. You will be informed who you should contact to obtain repairs that may be needed.